**DESCRIPTION****PLAN**

DESCRIPTION	PLAN
Parts, line drawing	B - 0.6.1 - 2
Parts, part numbers	B - 0.6.1 - 3
Line drawing, cord set, fan unit	B - 0.6.1 - 4
Cord set, fan units, table	B - 0.6.1 - 5
Nozzle, Hose & Tube, line drawing	B - 0.6.1 - 6
Nozzle, Hose & Tube, part numbers	B - 0.6.1 - 7

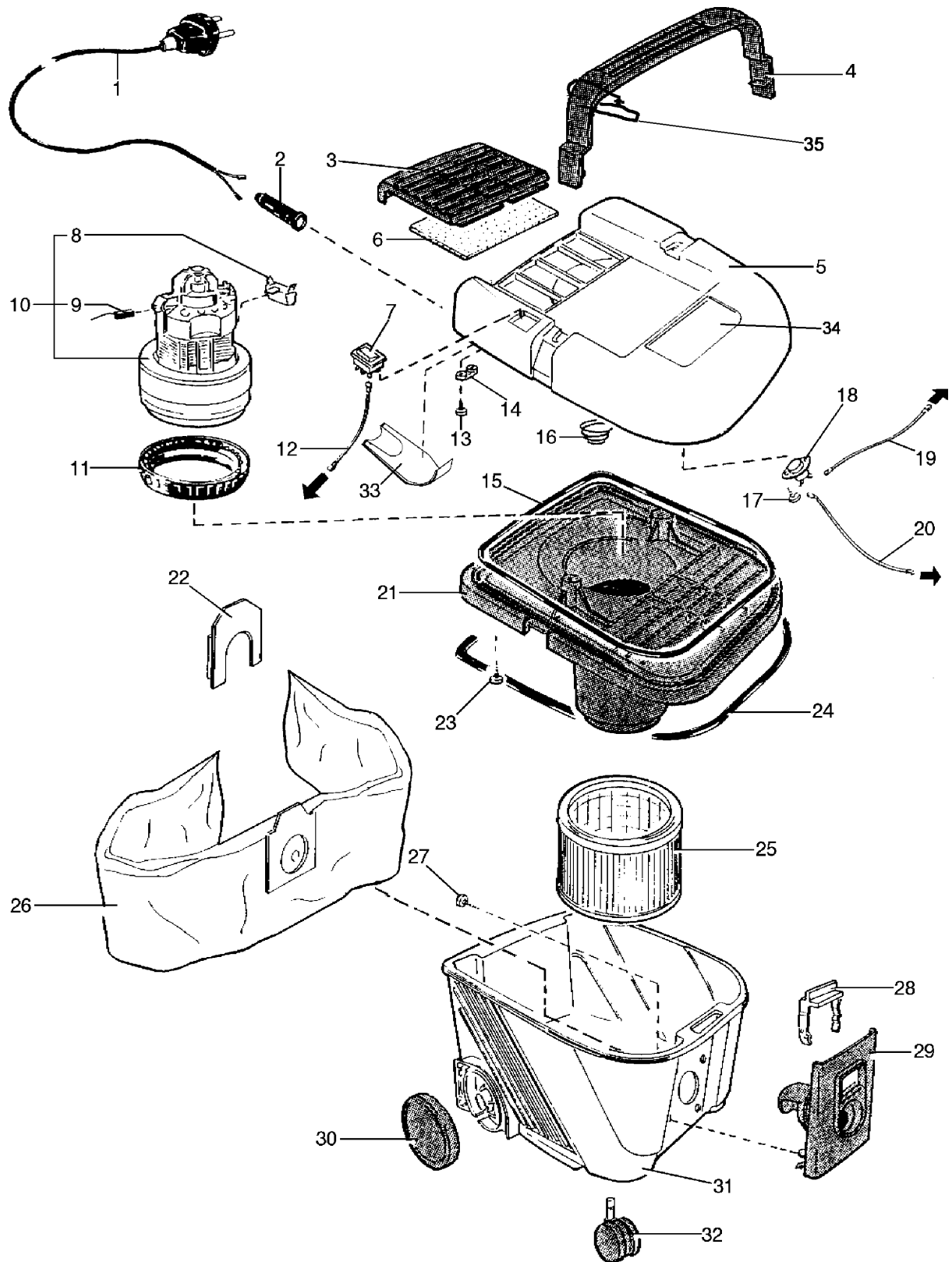

00-12	PARTS LIST	BOOK B		
01-06	UZ 934 PART NUMBER	B	0.6.1	3

Item.	Qty.	Part No	Description
1	1	<i>See table</i>	Cord set
2	1	<i>See table</i>	Protection sleeve
3	1	140 6873 000	Grating
4	1	140 6872 000	Handle
5	1	140 6871 000	Upper cover, neutral blue
	1	140 6871 010	Upper cover,neutral blue UL approved
	1	140 6871 040	Upper cover, grey
	1	140 7314 020	Upper cover, KENT UL-approved, blue
	1	140 7314 030	Upper cover, Euroclean UL-approved, blue
6	1	140 6879 000	Diffuser
7	1	140 5496 000	Switch
8	1	140 8166 010	Capacitor
9	2	001 8619 110	Carbon brush (without holder)
	2	140 7719 000	Carbon brush f.140 7902 520 fan units. w. holder 230-240V
	2	140 7720 000	Carbon brush f.140 7902 510 fan units. w. holder 110-120V
	2	140 7721 000	Carbon brush f.140 7902 530 fan units. w. holder 100V
10	1	<i>See table</i>	Fan unit
11	1	140 7901 000	Suspension ring, for the new Domel fan units (the 140 7902 XXX)
	1	011 1548 000	Suspension ring, for the old type of motor
12	1	140 7040 080	Wire cpl.
	1	140 7042 110	Wire cpl. <i>UL-approved</i>
13	2	140 9214 040	Screw
14	1	056 1014 060	Anti-strain clip
15	1	140 6876 000	Gasket
16	2	140 7016 000	Spring
17	1	140 6843 000	Screw
18	1	140 3894 000	Thermal protector
19	1	140 7040 110	Wire cpl.
	1	140 7042 090	Wire cpl. <i>UL-approved</i>
20	1	140 7040 030	Wire cpl.
	1	140 7042 100	Wire cpl. <i>UL-approved</i>
21	1	140 6870 000	Lower cover.
	1	140 6870 010	Lower cover, <i>UL-approved</i>
22	1	140 6744 000	Lock Washer
23	6	140 7027 010	Screw
24	2	140 6875 000	Gasket
25	1	140 6880 000	Air filter
26		140 6905 020	Dust bag 10-pcs.
27	4	140 9214 040	>>Screw, Torx 40x14
28	1	140 6411 000	Hose locking
	1	140 7205 010	Hose locking, more curved
29	1	140 6409 000	Hose connection
30	2	011 5840 030	Wheel
31	1	140 6408 000	Container Blue
	1	140 6408 050	Container Grey
	1	140 6428 000	Container cpl. Blue
	1	140 6428 050	Container cpl. Grey
32	2	140 6422 000	Castor wheel
33	1	140 6960 000	Insulation cover
	1	140 6960 010	Insulation cover, <i>UL-approved</i>
34		140 7775 000	Sticker - decal, Nilfisk label
35	1	140 7860 000	Holder for cabel, for 905 2513 (US variants)

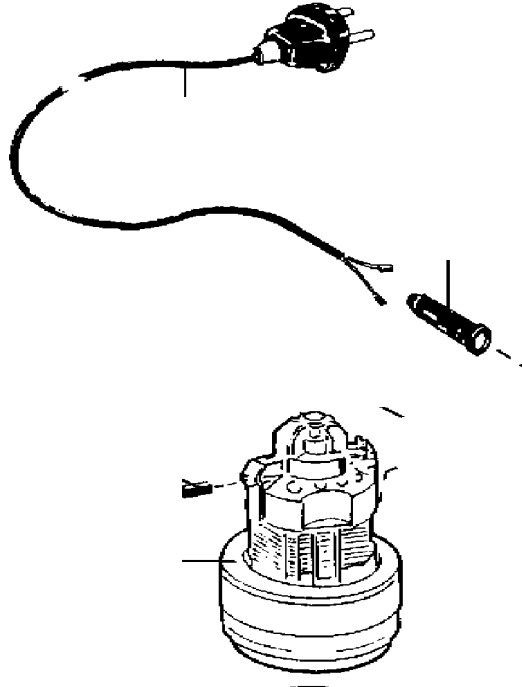

Prod. No	Voltage	☐	⏚	Cord set	Protection sleeve	Fan unit
905 2501 Blue	230-240V 50/60Hz	X		140 6423 020	140 7035 000	140 7902 520
905 2502 Blue	230-240V 50/60Hz	X		140 6423 060	140 7035 000	140 7902 520
905 2503 Blue	230-240V 50/60Hz	X		140 6676 000	140 7035 000	140 7902 520
905 2504 Blue	100V 50/60Hz	X		140 6423 040	093 1027 010	140 7902 530
905 2505 Blue	230-240V 50/60Hz	X		140 6423 070	140 7035 000	140 7902 520
905 2506 Blue	110V 50/60Hz	X		140 6423 130	140 7035 000	140 7902 510
905 2507 Blue	120V 50/60Hz	X		140 6423 040	093 1027 010	140 7902 510
905 2508 Blue	120V 50/60Hz		X	140 3859 040	093 1027 010	140 7902 510
905 2509 Blue	220V 50/60Hz		X	140 6423 220 +plug 093 1043 020	093 1027 010	140 7902 520
905 2510 Blue	110V 50/60Hz	X		140 6423 040	093 1027 010	140 7902 510
905 2511 Yellow	230-240V 50/60Hz	X		140 6423 060	140 7035 000	140 7902 520
905 2512 Yellow	230-240V 50/60Hz	X		140 6423 020	140 7035 000	140 7902 520
905 2513 Blue	120V 50/60Hz		X	140 3859 040	093 1027 010	140 7902 510
905 2514 Blue	127V 50/60Hz	X		140 6423 040	093 1027 010	140 7902 540
905 2416 Blue	230-240 V 50/60Hz	X		140 6423 090	140 7035 000	140 7902 520
905 2517 Blue	230-240V 50/60Hz	X		>>140 6423 060	140 7035 000	140 7902 520
905 2518 Grey	230-240V 50/60Hz	X		140 6423 020	140 7035 000	140 7902 520
905 2519 Grey	230-240V 50/60Hz	X		140 6423 070	140 7035 000	140 7902 520
905 2520 Grey	220-240V 50/60Hz	X		140 6423 060	140 7035 000	140 7902 520
905 2521 Grey	230-240V 50/60Hz	X		140 6676 000	140 7035 000	140 7902 520
905 2522 Grey	230-240V 60Hz	X		140 6423 040	093 1027 010	140 7902 520
905 2523 Grey	230-240V 50/60Hz	X		140 6423 040	093 1027 010	140 7902 520
905 2524 Blue	115v 50/60Hz	X		140 6423 320	140 7035 000	
905 2540 Grey prod. f. Yamasaki	100V 50/60Hz	X		140 6423 040	093 1027 010	140 7902 530
>>905 2541 Grey	127V 50/60Hz	X		140 6423 040	093 1027 010	140 7902 540
>>905 2542 Grey	230-240v 50/60Hz	X		140 6423 090	140 7035 000	140 7902 520
>>905 2543 Grey	115v 50/60Hz	X		140 6423 320	140 7035 000	140 7902 510

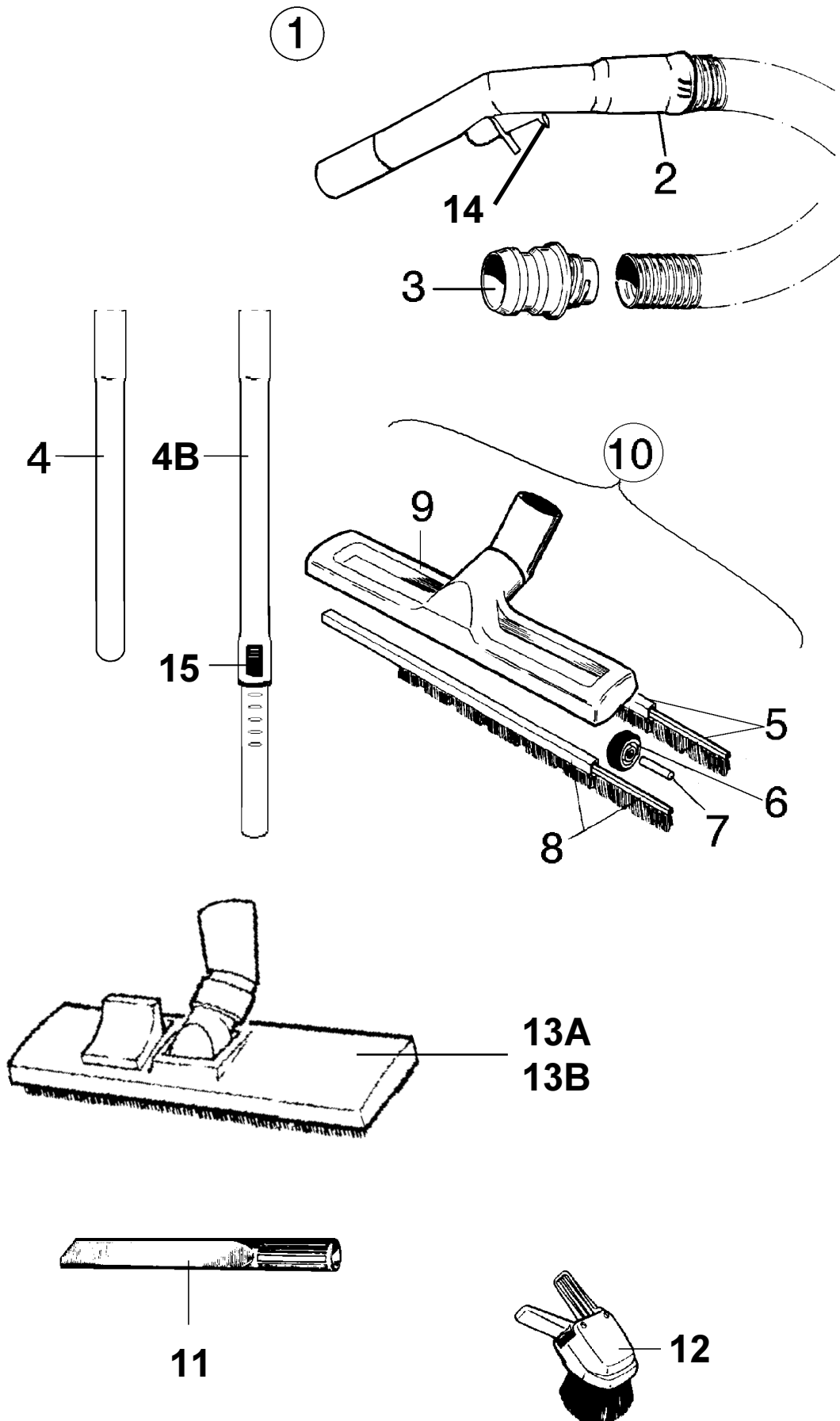

00-12	PARTS LIST	BOOK B		
01-06	UZ 934 NOZZLE, HOSE & TUBE	B	0.6.1	7

Item.No.	Qty.	Part No	Description
1	1	140 6430 000	Hose complete
2	1	140 7584 000	Bent end cpl.
3	1	140 3304 020	Inlet sleeve
4	2	011 6431 040	Extension tube 50 cm, aluminium
	2	11112401	Extension tube 56 cm, steel
4B	1	011 8130 040	Telescopic extension tube, min 630 mm max 950 mm.
5	1	140 8741 010	Brush strip, rear
6	2	140 8743 000	Wheel
7	2	140 8744 000	Shaft
8	1	140 8741 000	Brush strip, front
9	1	140 8740 000	Top
10	1	140 6700 010	Multi surface nozzle compl.
11	1	010 3098 250	Crevice nozzle
12	1	011 3104 230	Small combi nozzle
13A	1	140 8245 000	Combination nozzle black
13B	1	11980300	Combination nozzle grey w. Nilfisk brandname
14	1	012 5475 000	Rubber packing
15	1	011 8136 020	Regulator

>> Means: New or changed ref. number or/and changed/new specifications

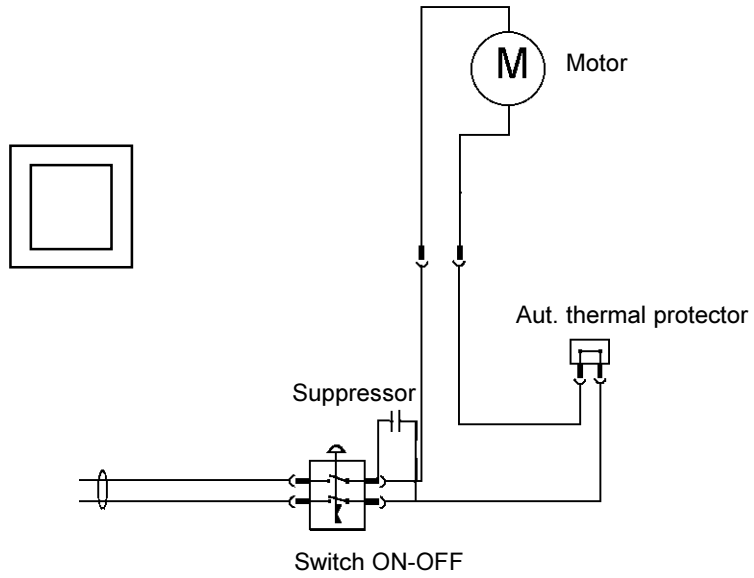

Note: Wiring diagram only for Domel fan units p/n 140 7902 xxx.

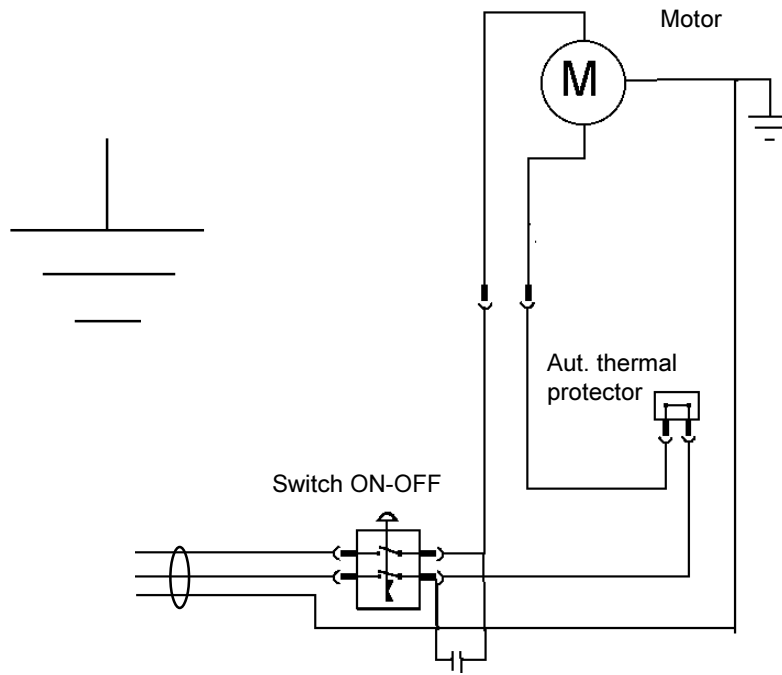

Suppressor *

* Not for US versions

Note: Wiring diagram only for Domel fan units p/n 140 7902 xxx.