

ORECK[®] XL[®]

SIMPLY AMAZING[®]

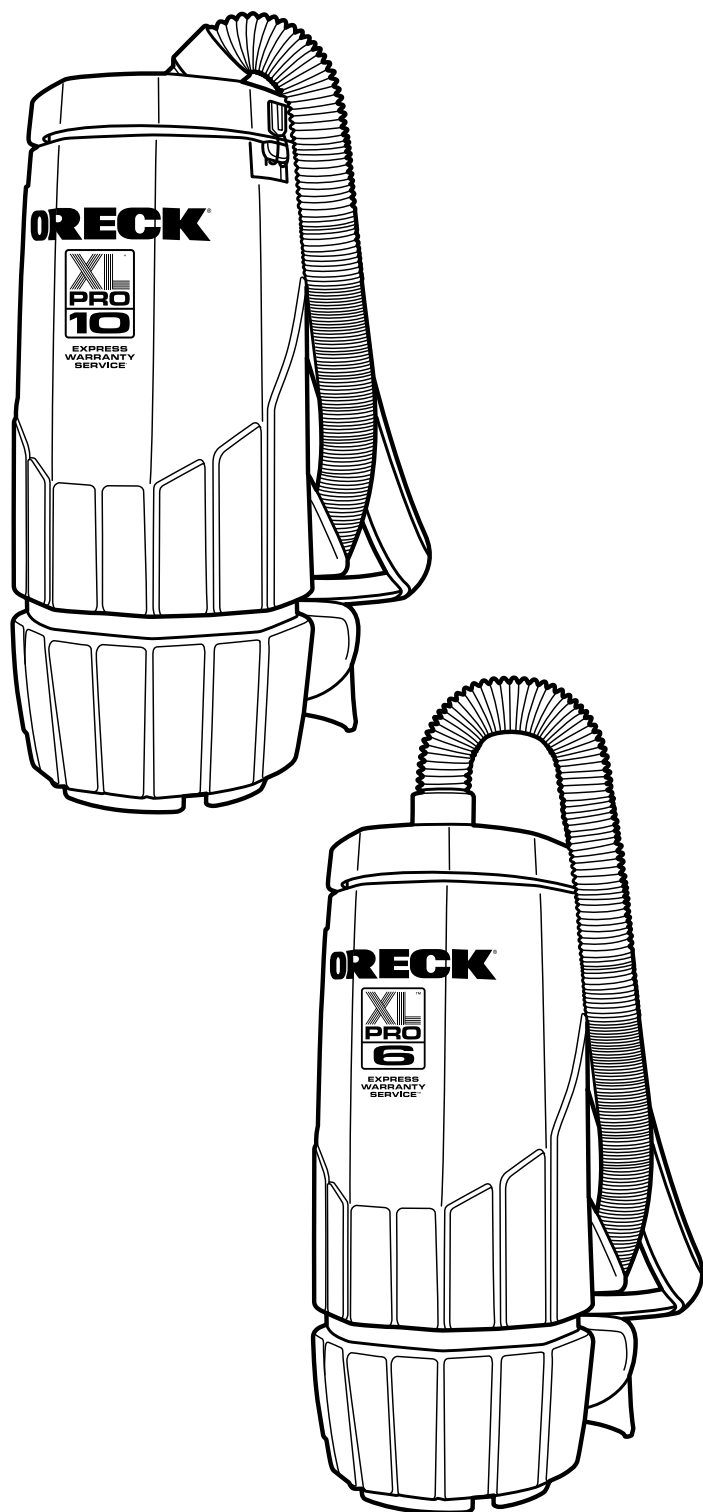

USER'S GUIDE

BackPack Vacuum

XLPRO6A

XLPRO10A

XLPRO6Z

• **IMPORTANT!**
SAVE THIS BOOKLET!

Includes:

- Warranty
- Safety Warnings
- Parts List
- Operating Instructions
- Accessories List
- Trouble Diagnosis

BEFORE OPERATING, READ ALL INSTRUCTIONS IN THIS MANUAL CAREFULLY.

Table of Contents

Warranty, Important Safety Instructions	page	2
Maintenance & Customer Service, Vacuum Cleaner Care, Operation & Assembly, Grounding Instructions, Adjustment Instructions	page	3
Troubleshooting Guide, Parts Listing, Parts Diagram, Accessories	page	4

Warranty

ORECK MANUFACTURING COMPANY: (Oreck gives you the following limited warranty for this product only if it was originally purchased for use, not resale, from Oreck or an Oreck Authorized Retail Dealer.)

Oreck will repair or replace, free of charge, to the original purchaser, any part which is found to be defective in material or workmanship within one (1) year of the date of purchase.

This limited warranty does not apply to any part subjected to accident, abuse, or alteration, misuse, damage caused by fire or act of God, the use of voltages other than indicated on the serial number plate of this product or service of this product by other than Oreck or an Oreck Factory Authorized Service Center.

Oreck does not authorize any person or representative to assume or grant any other warranty obligation with the sale of this product.

Oreck's limited warranty is valid only if you retain proof of purchase from Oreck or an Oreck Authorized Retail Dealer for this product. If you purchase this product from any other source, your purchase is "AS IS," which means Oreck grants you no warranty, and that you, not Oreck, assume the entire risk of the quality and performance of this product, including the entire cost of any necessary servicing or repairs of any defects.

Oreck's liability for damages to you for any costs whatsoever arising out of this statement of limited warranty shall be limited to the amount paid for this product at the time of original purchase, and Oreck shall not be liable for any direct, indirect, consequential or incidental damages arising out of the use or inability to use this product.

Some states do not allow the exclusion or limitation of incidental or consequential damages, so the above limitation or exclusion may not apply to you.

ALL EXPRESS AND IMPLIED WARRANTIES FOR THIS PRODUCT, INCLUDING IMPLIED WARRANTIES OF MERCHANTABILITY AND FITNESS FOR A PARTICULAR PURPOSE, ARE LIMITED IN DURATION TO THE WARRANTY PERIOD, AND NO WARRANTIES, WHETHER EXPRESS OR IMPLIED, WILL APPLY AFTER THIS PERIOD.

Some states do not allow limitations on the duration of implied warranties, so the above limitation may not apply to you.

This warranty gives you specific legal rights, and you may also have other rights which vary from state to state.

IMPORTANT SAFETY INSTRUCTIONS

When using an electrical appliance, basic precautions should always be followed, including the following:

READ ALL INSTRUCTIONS BEFORE USING THIS VACUUM

WARNING

To reduce the risk of fire, electric shock, or injury:

- DO NOT leave the vacuum when plugged in. Unplug from the outlet when not in use and before servicing.
- To avoid electric shock, DO NOT expose to rain. Store indoors. DO NOT use on wet surfaces.
- This is NOT a toy. Close attention is necessary when used around or near children.
- Use only as described in this safety manual. Use only manufacturer's recommended attachments and accessories.
- DO NOT use this vacuum with damaged cord or plug. If the vacuum is not working as it should, because it has been dropped, damaged, left outdoors or dropped into water, return to a service center or call customer service at:
COMMERCIAL: 1-800-336-0433
HOSPITALITY: 1-888-23-ORECK
CANADA: 1-888-67-ORECK
- DO NOT pull or carry by the cord, use cord as a handle, close a door on cord or pull cord around sharp edges and corners. Keep cord away from heated surfaces.
- DO NOT unplug the vacuum by pulling on the cord. To unplug, grasp the plug, not the cord.
- DO NOT handle the plug of the vacuum with wet hands.
- DO NOT put any objects into openings. DO NOT use with any opening blocked; keep free of dust, lint, hair and anything that may reduce air flow.
- Keep hair, loose clothing, fingers, and all parts of body away from openings and moving parts.
- DO NOT pick up anything that is burning or smoking, such as cigarettes, matches, or hot ashes.
- DO NOT use without dust bag and/or filters in place.
- DO NOT use the vacuum to pick up flammable or combustible liquids such as gasoline or use in areas where they may be present.
- Use extra care when cleaning stairs.
- DO NOT use where oxygen or anesthetics are used.
- Turn off all controls before unplugging
- The extension cord provided with this unit is 50 feet, #16, 3 wire and MUST be used with this unit to insure grounding protection.
- Replace damaged or worn parts immediately with genuine original equipment parts to maintain safety and to protect your limited warranty.
- BackPack Vacuum can become heavy during use. To avoid injury, DO NOT bend over while the BackPack Vacuum is on your back.

SAVE THESE INSTRUCTIONS

Maintenance and Customer Service

Your XLPro is a product of precise engineering. If you require additional information or have problems with your Oreck appliance, you may call ORECK customer service at:

COMMERCIAL: 1-800-336-0433
HOSPITALITY: 1-888-23-ORECK
CANADA: 1-888-67-ORECK

Please specify the model number and serial/code number which can be found on the data plate on the back of the vacuum.

Save your sales or purchase slip. Should your Oreck appliance require warranty service in the U.S.A., present this slip to the Authorized Service Center as your proof of purchase date or, in Canada, call customer service.

Vacuum Cleaner Care

Treat your vacuum cleaner as you would any other high grade precision made product. Dropping and other misuses may result in a damaged unit which will not be covered by warranty.

When not in use, the power cord should be wrapped around the molded-in cord wrap for storage. After each use, wipe the vacuum body, accessories and power cord with a damp cloth.

Read this manual completely before operating this vacuum. It is important to follow the instructions in the manual to prevent the possibility of injury or damage to the user and/or machine.

Operation & Assembly

This vacuum is equipped with an air-thru motor and is designed for dry pickup only. Unpack the carton and remove the vacuum and attachments. The backpack comes assembled; you will need to install the hose and attachments.

NOTE: Some accessories are packed inside the unit.

To Change Paper Filter Bag

1. **XLPRO6A / XLPRO6Z:** Turn top lid of vacuum a half turn counterclockwise and remove from the body. **XLPRO10A:** Release clips and remove lid.
2. Remove full paper bag from the tank and dispose of properly.
3. Expand paper filter bag and set inside the cloth filter.
4. **XLPRO6A / XLPRO6Z:** Reinstall top lid and turn a half turn clockwise to tighten. **XLPRO10A:** Reinstall top lid and fasten clips.



CAUTION: Always exercise caution when handling the vacuum. Dropping the vacuum could cause permanent damage to the internal components.

Cloth Filter Maintenance

The cloth filter should be cleaned each time you empty the tank. DO NOT WASH the cloth filter because shrinkage of the cloth and damage to the gasket can occur. To clean the cloth filter, shake off loose particles and brush exposed surface with a soft bristle brush.

To Connect Hose

1. Connect the non-swivel end of the hose into the inlet on top of vacuum.
2. Connect the swivel end of hose to the wand or tool you are planning to use.

Wand Assembly

The two piece wand requires some assembly.

1. Align the button lock of the upper wand section with the opening for button lock in the lower wand section.
2. Push sections together; unit lock is accomplished.



To Assemble Tools

1. Turn wand nut counterclockwise approximately four complete turns.
2. Insert the tool into wand and coupling.
3. While holding tool in place, turn nut clockwise until wand nut is fully locked.



Grounding Instructions

DANGER: Improper use of the grounding plug can result in a risk of electric shock.

Electrical equipment must be grounded. If it should malfunction or break, grounding provides a path of least resistance for electrical current to reduce the risk of electric shock. The vacuum is equipped with a cord having an equipment-grounding conductor and grounding plug. The plug must be inserted into an appropriate outlet that is properly installed and grounded in accordance with all local codes and ordinances.

If repair or replacement of the cord or plug is necessary, bring unit to an authorized service center. This electric equipment is for use on a nominal 120 volt circuit, and has a grounded plug that looks like the plug illustrated in (Fig A).

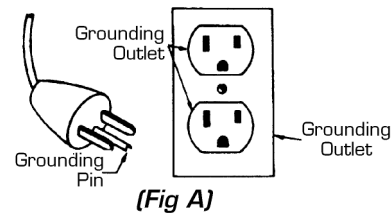

WARNING: Improper connection of the equipment-grounding conductor can result in a risk of electric shock. Check with a qualified electrician or service person if you are in doubt as to whether the outlet is properly grounded.

DO NOT modify the plug provided with the equipment. If it will not fit the outlet, have a proper outlet installed by a qualified electrician.

NOTE: In Canada, the use of a temporary adaptor is not permitted by the Canadian Electrical Code.

Adjustment Instructions

Proper fitting and adjustment of the straps is necessary to ensure fatigue free use. The **most important** item to remember when adjusting the shoulder straps and the hip belt is that **it is the hip belt that supports the Backpack, not the shoulder straps**. The shoulder straps are there to provide stability to balance the load, **NOT** to bear the weight.

Hip Belt

Loosen the shoulder straps and the hip belt and place the BackPack on your back with your arms through the shoulder straps. Position the belt on your hips. This should be about 2" below where you would wear a normal belt. Connect the male and female connectors together. Grasp the adjustment strap on each side of the hip belt connector and pull out, parallel to the ground, until the hip belt is firmly cinched to your hips.



Shoulder Straps

Now that you have the hip belt in place and tightened you may adjust the shoulder straps. Grasp the adjustment strap at the bottom of each shoulder pad and pull the straps downward until the straps are fitted to your body. When properly adjusted you should be able to slide two fingers under the strap on top of your shoulder. **Any irritation around the shoulder area indicates your shoulder straps are too tight.**



Troubleshooting Guide



CAUTION: Always disconnect power cord before servicing vacuum.

WARNING: Repairs should only be performed by an authorized service center.

<p>Problem: Loss of Vacuum</p> <p>Cause:</p> <ol style="list-style-type: none"> 1. Damaged lid. 2. Full paper filter bag. 3. Clogged hose or wand. 	<p>Solution:</p> <ol style="list-style-type: none"> 1. Inspect and replace if needed. 2. Replace paper filter bag. 3. Remove obstruction.
<p>Problem: Dust blowing from vacuum when running.</p> <p>Cause:</p> <ol style="list-style-type: none"> 1. Full paper filter bag. 2. Improperly installed paper filter bag. 3. Cloth filter bag dirty. 	<p>Solution:</p> <ol style="list-style-type: none"> 1. Replace filter bag. 2. Reinstall or replace paper filter bag. 3. Clean cloth filter bag.

ALL OTHER SERVICING SHOULD BE DONE BY AN ORECK AUTHORIZED SERVICE CENTER.

**CALL CUSTOMER SERVICE HOT LINE
TOLL FREE :1-800-353-9991**

Whenever calling, please be sure to have your model and serial number from data plate.

XLPRO6A & XLPRO6Z Parts Listing

Item #	Part #	Description
1	10-0001-6-O	6 Qt Body
2	10-0002-6-O	6 Qt Lid
6	PK25PRO6DW	6 Qt Paper Bag, 25 Pk
7	10-0496	6 Qt Cloth Bag
8	10-0008-A	Complete Dome Filter
12	10-0012	Motor
14	10-0014	Screws, Motor
15	10-0015	Washers, Motor
16	10-0016	Motor Deflector Plate
17	10-0017	Screw, Motor Deflector
18	10-0018	Sound Filter Band
19	10-0019	Dual Cell Noise Filter
20	10-0020	Cushioned Back Pad
21	10-0021	Waist Belt (Not Shown)
22	10-0022	Screw, Waist Belt
23	10-0023	Washer, Waist Belt
25	10-0025	On/Off Switch
26	10-0026-A	Power Cord, 17"
28	COMMCORD	50' Electrical Cord
38	10-0069	Cushion Support Clamp
39	10-0070	Screw (Cord Lock)
40	10-1333	Set, Motor Brushes
43	10-0165	Copper Ring (Not Shown)
44	10-0223-B	Collar, Nut & Copper Ring Set (Not Shown)

Accessories

Item #	Part #	Description
29	10-0029	2 Pc Aluminum Wand, Button
	10-0030-A	2 Pc Aluminum Wand, Friction
31	10-0031	5" Upholstery Tool
32	10-0032	14" Scalloped Floor Tool
33	10-0033	17" Crevice Tool
36	10-0036	Stretch Hose w/Cuffs
37	10-0037	3" Dust Brush
41	10-0183-A	Floor Replace Brush
42	10-0183	Bristle, Floor Tool

Parts Diagram

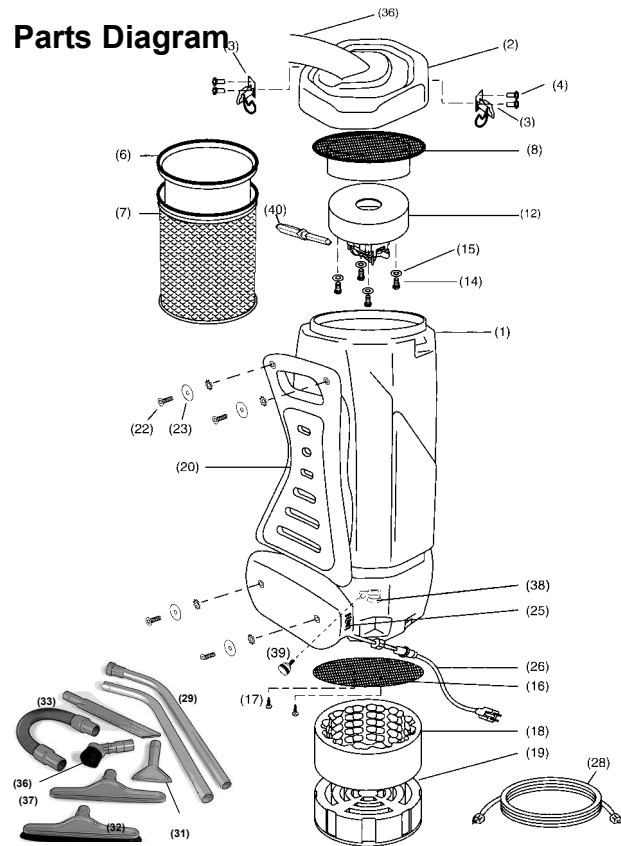

XLPRO10A Parts Listing

Item #	Part #	Description
1	10-0001-O	10 Qt Body
2	10-0002-O	10 Qt Lid, Complete
3	10-0003	Lid Latch
4	10-0004	Lid Rivet
6	PK25PRO10DW	10 Qt Paper Bag, 25 Pk
7	10-0007-A	10 Qt Cloth Bag
8	10-0008-A	Complete Dome Filter
12	10-0012	Motor
14	10-0014	Screws, Motor
15	10-0015	Washers, Motor
16	10-0016	Motor Deflector Plate
17	10-0017	Screw, Motor Deflector
18	10-0018	Sound Filter Band
19	10-0019	Dual Cell Noise Filter
20	10-0020	Cushioned Back Pad
21	10-0021	Waist Belt (Not Shown)
22	10-0022	Screw, Waist Belt
23	10-0023	Washer, Waist Belt
25	10-0025	On/Off Switch
26	10-0026-A	Power Cord, 17"
28	COMMCORD	50' Electrical Cord
38	10-0069	Cushion Support Clamp
39	10-0070	Screw (Cord Lock)
40	10-1333	Set, Motor Brushes
43	10-0165	Copper Ring (Not Shown)
44	10-0223-B	Collar, Nut & Copper Ring Set (Not Shown)

Accessories

Item #	Part #	Description
29	10-0029	2 Pc Aluminum Wand, Button
	10-0030-A	2 Pc Aluminum Wand, Friction
31	10-0031	5" Upholstery Tool
32	10-0032	14" Scalloped Floor Tool
33	10-0033	17" Crevice Tool
36	10-0036	Stretch Hose w/Cuffs
37	10-0037	3" Dust Brush
41	10-0183-A	Floor Replace Brush
42	10-0183	Bristle, Floor Tool