

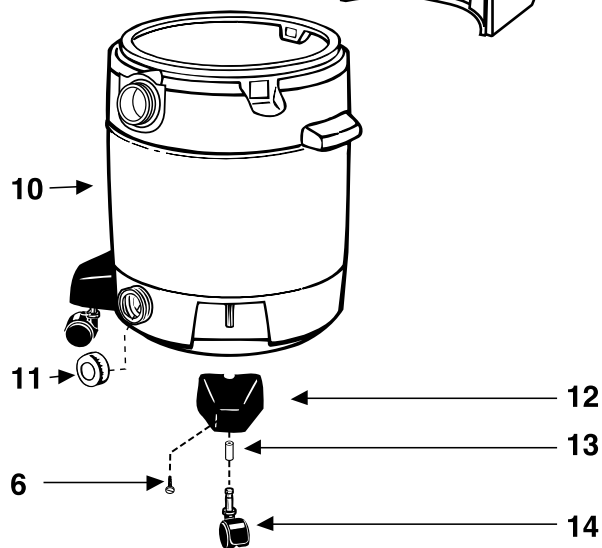

Model - 45A

Catalog 9253553
(10 Gal.)

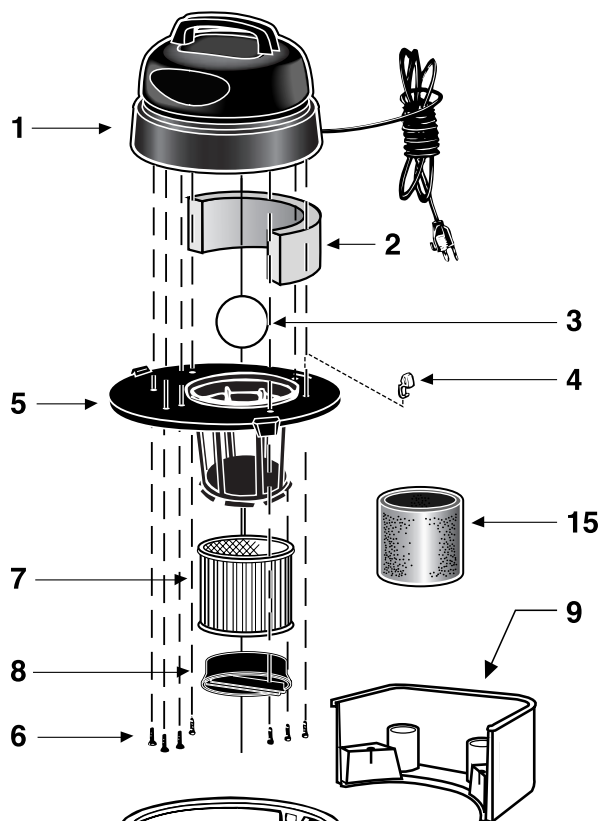
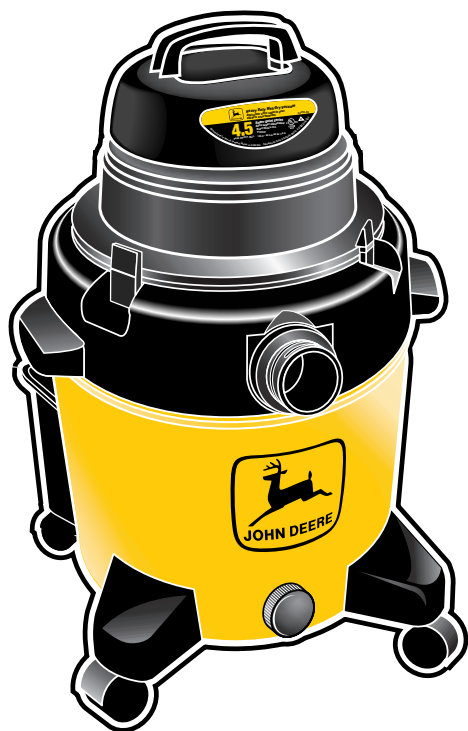

ITEM	DESCRIPTION	PART NO.
1	Power Unit Assembly	8111597
2	Foam Insert	1290508
3	Ball Float	0081100
4	Lid Latch	8550101
5	Lid Cage Assembly	8965724
6	Screw Hex Head #10 x 3/4 Type AB	1503999
7	Cartridge Filter	9030462
8	Filter Retainer	3008000
9	Accessory Caddy	8564000
10	Tank Assembly	8455897
11	Drain Cap	1062020
12	Caster Foot	8565000
13	Caster Retainer	8565500
14	Caster	6774200
15	Foam Sleeve	9058562

STANDARD ACCESSORIES

- 8' x 1 1/4" hose
- 2 - 1 1/4" extension wands
- 10" squeegee insert
- 1 1/4" gulper nozzle
- 1 1/4" crevice tool
- 1 1/4" round brush

Limited One-Year Warranty

Shop-Vac Corporation warrants all Industrial, Commercial, and Contractor vacuum cleaners for one year from date of purchase to correct by repair or parts replacement without charge any product defect due to faulty material or workmanship.