

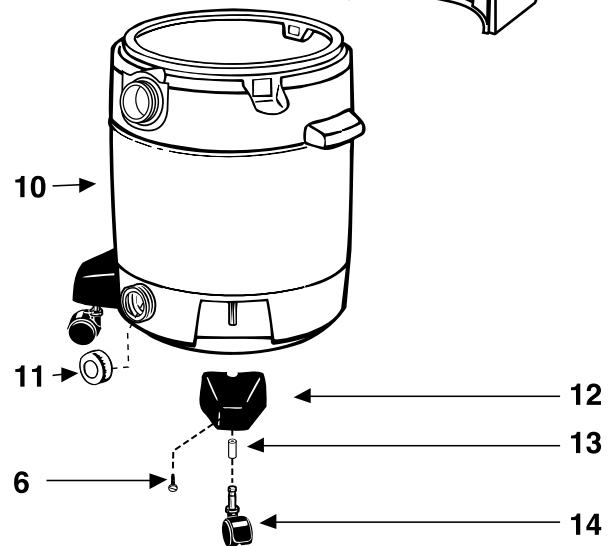

Model - 50A

Catalog 9253253
(14 Gal.)

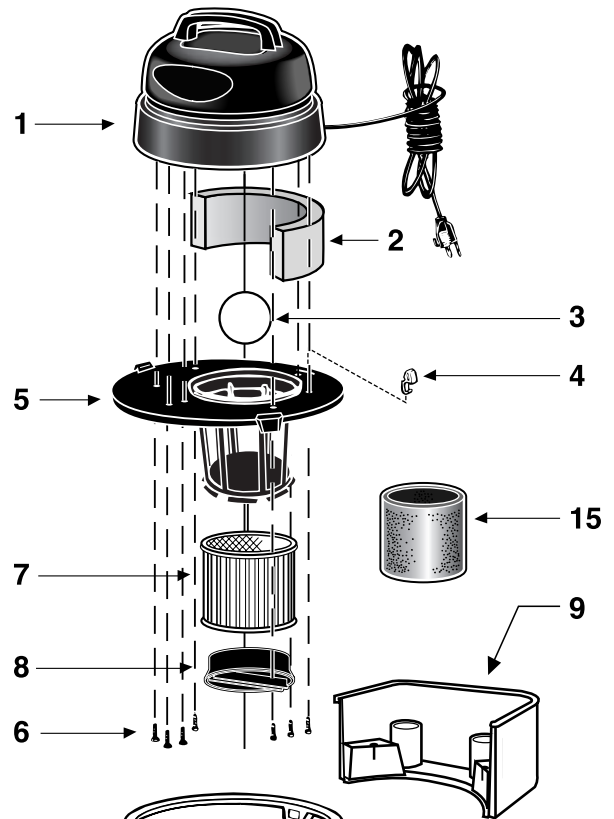
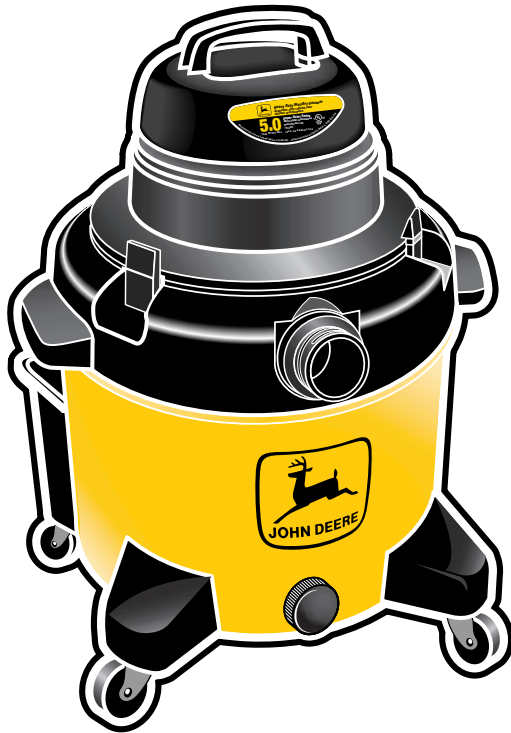

ITEM	DESCRIPTION	PART NO.
1	Power Unit Assembly	8111697
2	Foam Insert	1290508
3	Ball Float	0081100
4	Lid Latch	8550101
5	Lid Cage Assembly	8988724
6	Screw Hex Head #10 x 3/4 Type AB	1503999
7	Cartridge Filter	9030462
8	Filter Retainer	3008000
9	Accessory Caddy	8564200
10	Tank Assembly	8451697
11	Drain Cap	1062020
12	Caster Foot	8565101
13	Caster Retainer	8565500
14	Caster	6774200
15	Foam Sleeve	9058562

STANDARD ACCESSORIES

- 6' x 2 1/2" hose
- 2 - 2 1/2" extension wands
- 6" utility nozzle
- 14" Floor nozzle
- 14" squeegee insert
- 2 1/2" crevice tool
- 2 1/2" gulper nozzle

Limited One-Year Warranty

Shop-Vac Corporation warrants all Industrial, Commercial, and Contractor vacuum cleaners for one year from date of purchase to correct by repair or parts replacement without charge any product defect due to faulty material or workmanship.