

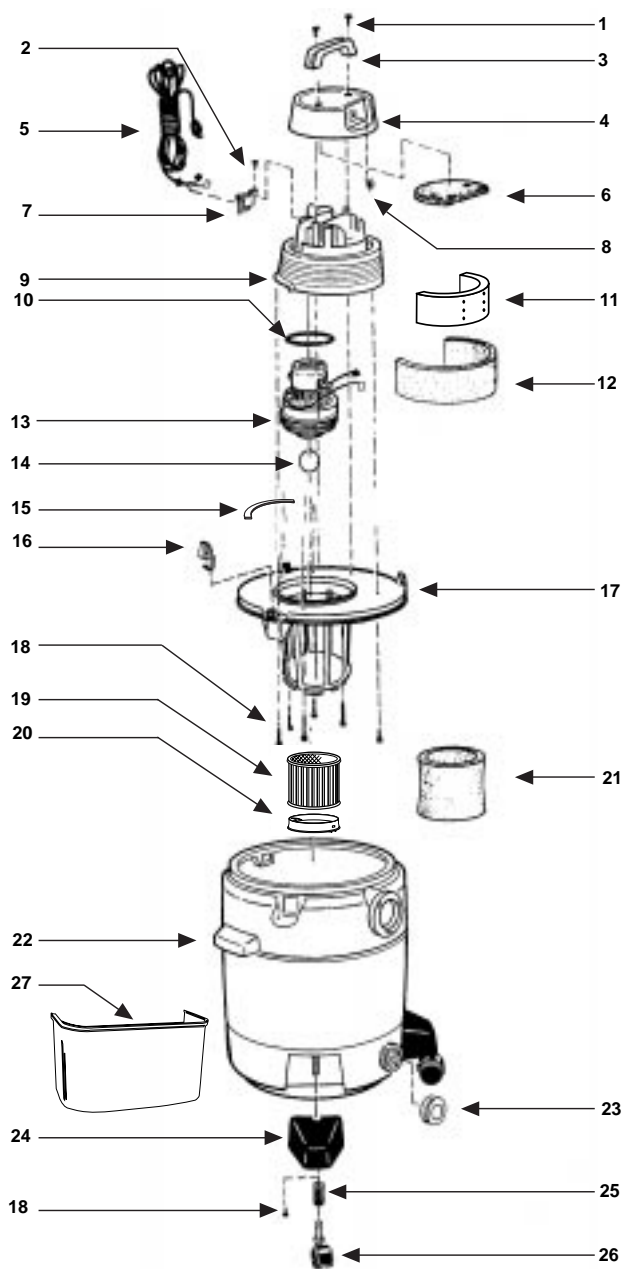

Model - 50

Catalog 925-32-53
(14 Gal.)



ITEM	DESCRIPTION	PART NO.
1	Screw Truss Head 1/4 x 3/4 Type AB	15146-99-6
2	Screw #8 x 1/2 Ph Pan Hd Type AB	15007-99-0
3	Top Handle	24105-00-9
4	Motor Housing Cover Assembly	24106-03-1
5	Cord	25800-23-6
6	Foam Insert Cover	24125-00-7
7	Cord Retainer	24111-12-2
8	Switch	82318-00-7
9	Motor Housing	24107-13-8
10	Upper Motor Gasket	20720-00-9
11	Inner Housing Acoustical Foam	12904-00-9
12	Outer Housing Acoustical Foam	12905-03-0
13	Motor	14967-97-0
14	Ball Float	00811-00-0
15	Strip Gasket	20711-00-8
16	Lid Latch	85501-01-3
17	Lid Cage Assembly	89887-14-5
18	Screw Hex Head #10 x 3/4 Type AB	15039-99-3
19	Cartridge Filter	90304-62-7
20	Filter Retainer	30080-00-6
21	Foam Sleeve	90585-62-1
22	Tank Assembly	10487-97-3
23	Drain Cap	10620-20-1
24	Caster Foot	85651-01-6
25	Caster Retainer	85655-00-9
26	Casters (Pkg. of 4)	42017-96-2
27	Accessory Caddy	85642-00-7

•STANDARD ACCESSORIES

- 6' x 2 1/2" hose
- 2 - 2 1/2" extension wands
- 6" utility nozzle
- 14" floor nozzle
- 14" squeegee insert
- 2 1/2" crevice tool
- 2 1/2" gulper nozzle

Limited One-Year Warranty

Shop-Vac Corporation warrants all Industrial, Commercial, and Contractor vacuum cleaners for one year from date of purchase to correct by repair or parts replacement without charge any product defect due to faulty material or workmanship.