

shop-vac®

# Model - 90L600A

Catalog 9301611  
(16 Gal.)



ITEM	DESCRIPTION	PART NO.
1	Handle	3753000
2	Switch Button - Red	7441510
3	Switch Button - Green	7441500
4	Spring	2802899
5	Motor Cover Assembly (Includes items 1-5)	3747011
6	Screw 10 x 3/4" Trilobe T25 Head	1516599
7	Power Unit Assembly	8130997
8	Float	3545000
9	Lid Latch	7441600
10	Lid Cage and Latch Assembly	1944104
11	Foam Sleeve	9058562
12	Cartridge Filter (Includes item 13)	9030462
13	Filter Retainer	3008000
14	Tank Assembly	7395197
15	Inlet Deflector	7413100
16	Rear Wheel Dolly/Tool Holder	7440210
17	Axle	7410900
18	Rear Wheel	7440400
19	Accessory Basket	9065800
20	Front Caster Dolly	7430250
21	Retainer	8565700
22	Caster	6773900
23	Screw 10 x 3/4" SL Hex Head	1503999
24	Drain Cover	7443422

**STANDARD ACCESSORIES**

- 8' x 2-1/2" hose
- 2 - 2-1/2" extension wands
- 14" floor nozzle w/brush

- 14" squeegee insert
- 2-1/2" crevice tool
- 8" utility nozzle
- hose holder

**FIVE-YEAR HOME USE WARRANTY - SATISFACTION GUARANTEED**

Your Shop-Vac® vacuum cleaner is warranted in normal household use, in accordance with the User Manual, against original defects in material and workmanship for a period of five years from date of purchase. Should this product be used for commercial or rental use, a 90 day limited warranty will apply. Shop-Vac Corporation warrants placing this vacuum cleaner in correct operating condition, by repair or parts replacement, during the warranty period, without charge. This warranty does not cover accessories. Use of non-recommended filters and/or accessories may void the manufacturer's warranty.

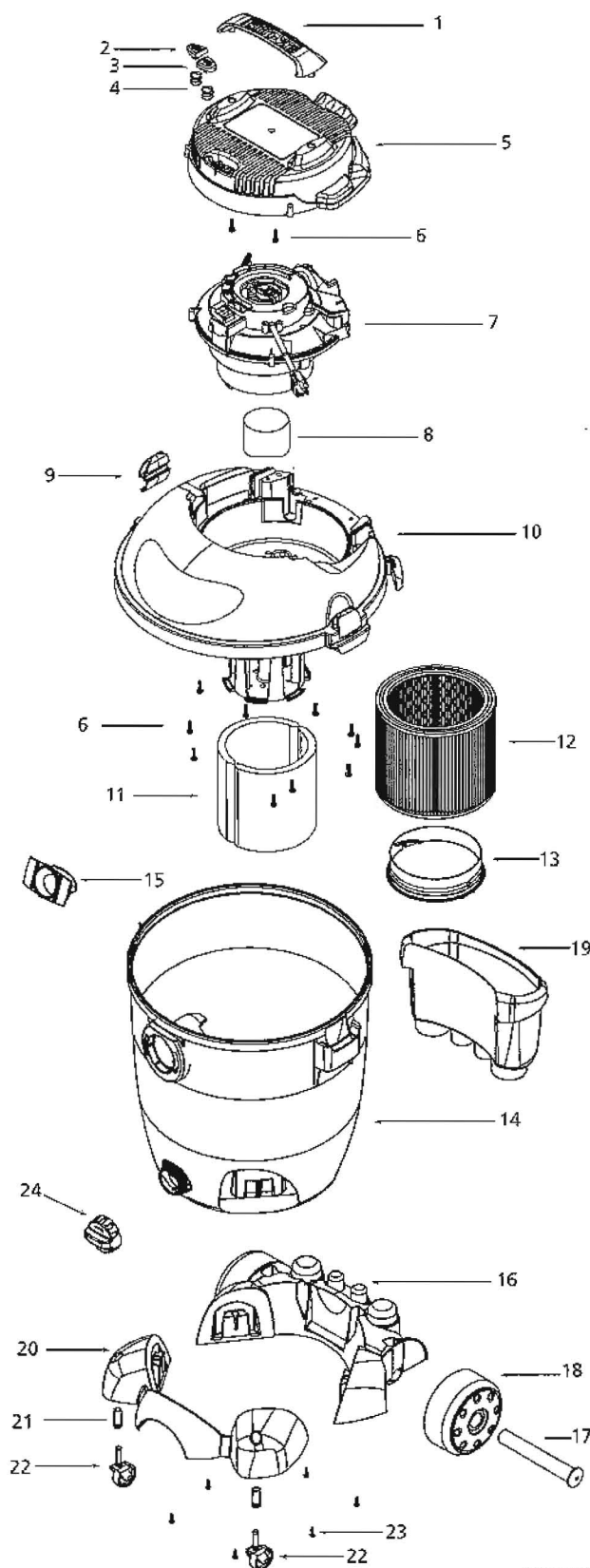

SC87529-19