

shop-vac®

Catalog 925-91

# Model QPV 10.5

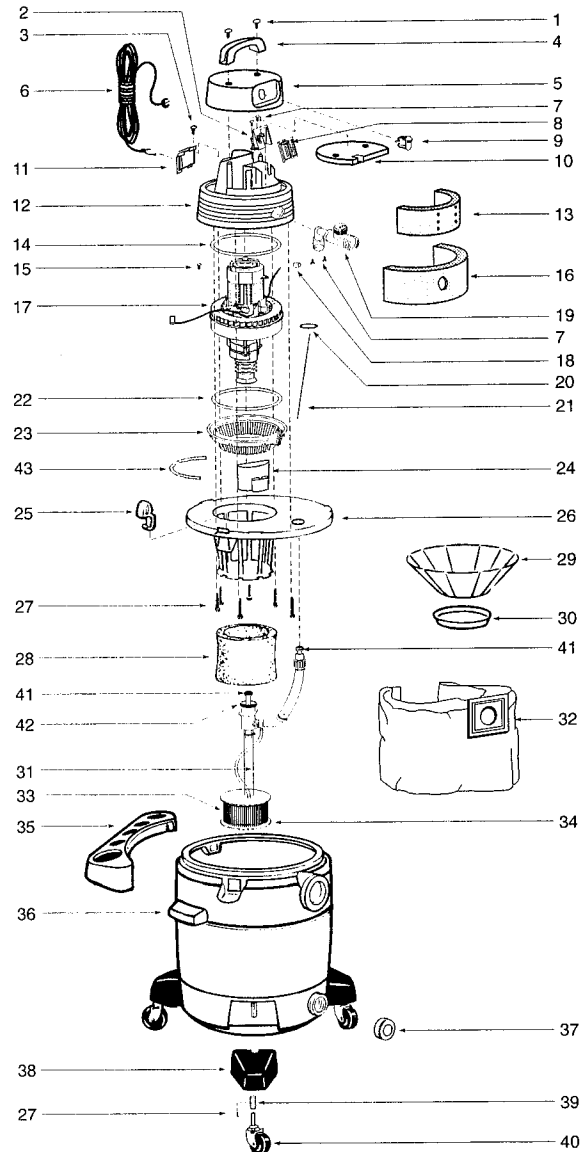
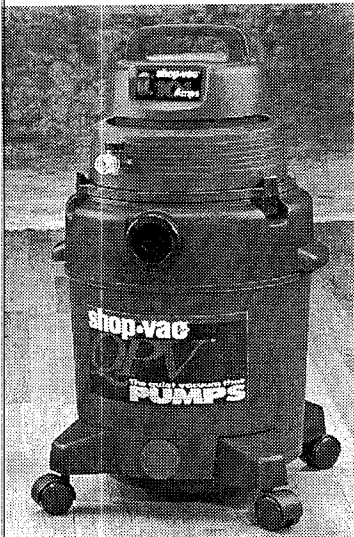

ITEM	DESCRIPTION	PART NO.
1	Screws Truss Head 1/4 x 3/4 Type AB	15146-99-6
2	Switch Assembly	27702-96-8
3	Screw #8 x 1/2 Ph Pan Hd Type AB	15007-99-0
4	Handle	24105-01-7
5	Motor Housing Cover	24106-04-9
6	Cord	25800-08-7
7	Screw #8 x 3/4 Ph Pan HD	15005-99-4
8	Link	27201-00-3
9	Switch Cover and Actuator Assembly	27740-96-8
10	Foam Insert Cover	24125-00-7
11	Cord Retainer	24111-15-5
12	Motor Housing	24107-67-4
13	Foam Motor Housing - Inner	12904-00-9
14	Gasket - Upper Motor	20700-00-1
15	Ground Screw	17008-99-5
16	Foam Motor Housing - Outer	27241-00-9
17	Motor	18167-97-3
18	Wire Nut	05001-99-5
19	Shut-Off Assembly	27700-96-2
20	O-Ring	74029-99-2
21	Float Rod	27232-00-8
22	Gasket-Lower Motor	20716-00-7
23	Grid Plate	27228-00-6
24	Float	27205-00-4
25	Lid Latch	85501-01-3
26	Lid Cage & Latch Assembly	27250-14-1
27	Screw #8 x 3/4 Ph Pan Hd Type AB	15039-99-3
28	Foam Sleeve	90585-62-2
29	Reusable Dry Filter	90107-62-4
30	Filter Ring	30065-00-7
31	Pump Adapter Kit (includes items 33 & 34)	27730-96-6
32	Collection Bag (pkg. of 3)	90662-62-8
33	Screen	27237-00-7
34	Cage Bottom	27225-00-2
35	Accessory Tool Holder	84111-00-4
36	Tank Assembly	10467-97-5
37	Drain Cap	10620-21-9
38	Caster Foot	85650-00-0
39	Caster Retainer	85655-00-9
40	Casters (pkg. of 4)	67742-00-7
41	O-Ring	74041-99-7
42	O-Ring	74040-99-9
43	Strip Gasket	20711-00-8

### STANDARD ACCESSORIES

- 7' x 1 1/4" hose with curved end and air diffuser
- 2 - 1 1/4" extension wands
- 10" wet/dry nozzle
- 10" squeegee insert

### THREE-YEAR HOME USE WARRANTY

Your Shop-Vac® vacuum cleaner is warranted in normal household use, in accordance with the User Manual, against original defects in material and workmanship for a period of three years from date of purchase. Should this product be used for commercial or rental use, a 90 day limited warranty will apply. Shop-Vac Corporation warrants placing this vacuum cleaner in correct operating condition, by repair or parts replacement, during the warranty period, without charge. This warranty does not cover accessories. Use of non-recommended filters and/or accessories may void the manufacturer's warranty.

Rev. 10/98  
SC87516-51

shop-vac®

Catalog 925-92

# Model QPV 10.5

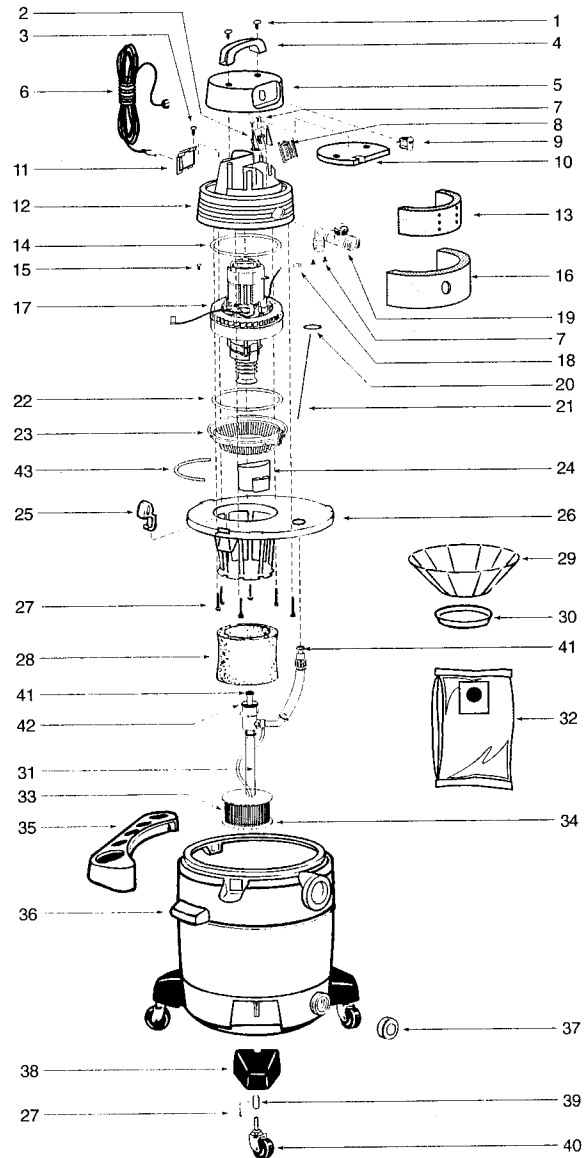

ITEM	DESCRIPTION	PART NO.
1	Screws Truss Head 1/4 x 3/4 Type AB	15146-99-6
2	Switch Assembly	27702-96-8
3	Screw #8 x 1/2 Ph Pan Hd Type AB	15007-99-4
4	Handle	24105-01-7
5	Motor Housing Cover	24106-04-9
6	Cord	25800-08-7
7	Screw #8 x 3/4 Ph Pan HD	15005-99-4
8	Link	27201-00-3
9	Switch Cover and Actuator Assembly	27740-96-8
10	Foam Insert Cover	24125-00-7
11	Cord Retainer	24111-15-5
12	Motor Housing	24107-67-4
13	Foam Motor Housing - Inner	12904-00-9
14	Gasket - Upper Motor	20700-00-1
15	Ground Screw	17008-99-6
16	Foam Motor Housing - Outer	27241-00-9
17	Motor	18167-97-3
18	Wire Nut	05001-99-5
19	Shut-Off Assembly	27700-96-2
20	O-Ring	74029-99-2
21	Float Rod	27232-00-8
22	Gasket-Lower Motor	20720-02-5
23	Grid Plate	27228-00-6
24	Float	27205-00-4
25	Lid Latch	85501-01-3
26	Lid Cage & Latch Assembly	27250-14-0
27	Screw #8 x 3/4 Ph Pan Hd Type AB	15039-99-3
28	Foam Sleeve	90585-62-1
29	Reusable Dry Filter	90107-62-4
30	Filter Ring	30065-00-7
31	Pump Adapter Kit (includes items 33 & 34)	27730-96-9
32	Collection Bag (pkg. of 3)	90663-62-6
33	Screen	27237-00-7
34	Cage Bottom	27225-00-2
35	Accessory Basket	85642-02-3
36	Tank Assembly	10470-97-9
37	Drain Cap	10620-21-9
38	Caster Foot	85650-00-0
39	Caster Retainer	85655-00-7
40	Casters (pkg. of 4)	67736-00-9
41	O-Ring	74041-99-7
42	O-Ring	74040-99-9
43	Strip Gasket	20711-00-8

### STANDARD ACCESSORIES

- 7' x 1 1/4" hose with curved end and air diffuser
- 2 - 1 1/4" extension wands
- 10" wet/dry nozzle
- 10" squeegee insert

### THREE-YEAR HOME USE WARRANTY

Your Shop-Vac® vacuum cleaner is warranted in normal household use, in accordance with the User Manual, against original defects in material and workmanship for a period of three years from date of purchase. Should this product be used for commercial or rental use, a 90 day limited warranty will apply. Shop-Vac Corporation warrants placing this vacuum cleaner in correct operating condition, by repair or parts replacement, during the warranty period, without charge. This warranty does not cover accessories. Use of non-recommended filters and/or accessories may void the manufacturer's warranty.

Rev. 10/98  
SC87516-53

shop-vac®

Catalog 925-93

# Model QPV 10.5

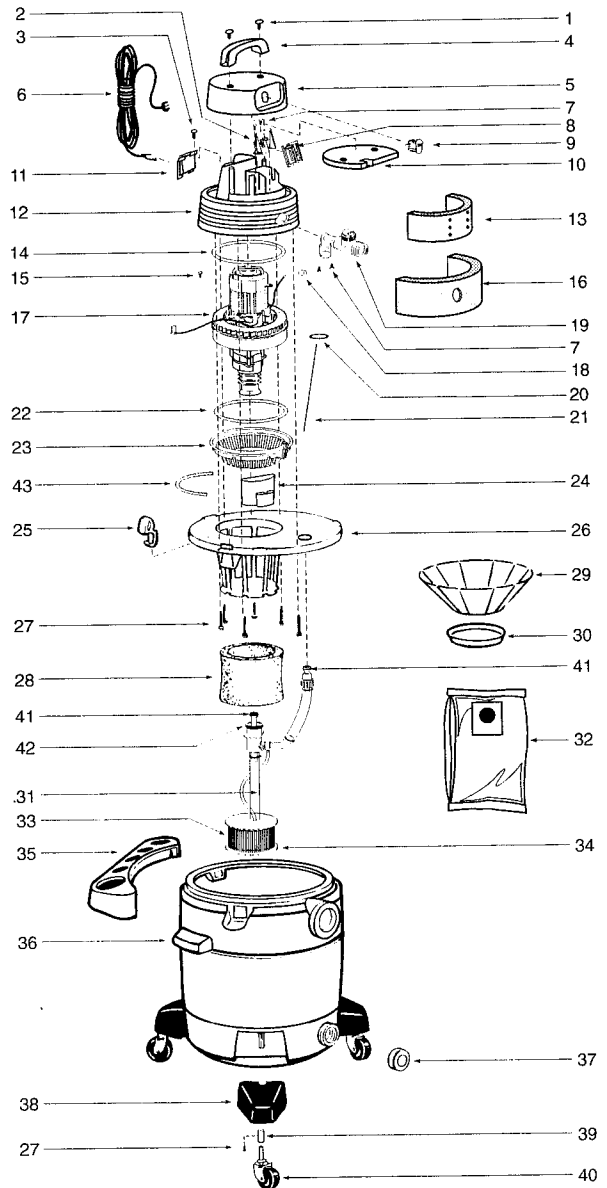
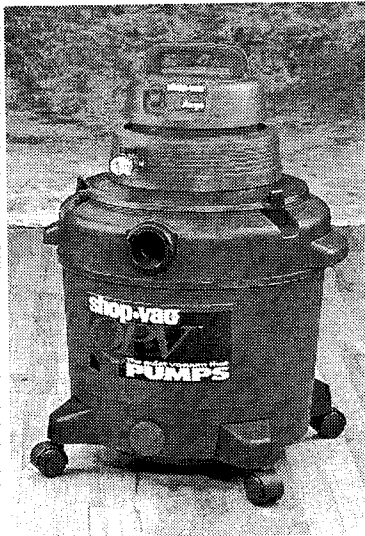

ITEM	DESCRIPTION	PART NO.
1	Screws Truss Head 1/4 x 3/4 Type AB	15146-99-6
2	Switch Assembly	27702-96-8
3	Screw #8 x 1/2 Ph Pan Hd Type AB	15007-99-0
4	Handle	24105-01-7
5	Motor Housing Cover	24106-04-9
6	Cord	25800-08-7
7	Screw #8 x 3/4 Ph Pan HD	15005-99-4
8	Link	27201-00-3
9	Switch Cover and Actuator Assembly	27740-96-8
10	Foam Insert Cover	24125-00-7
11	Cord Retainer	24111-15-2
12	Motor Housing	24107-67-4
13	Foam Motor Housing - Inner	12904-00-9
14	Gasket - Upper Motor	20700-00-1
15	Ground Screw	17008-99-5
16	Foam Motor Housing - Outer	27241-00-9
17	Motor	18167-97-3
18	Wire Nut	05001-99-5
19	Shut-Off Assembly	27700-96-2
20	O-Ring	74029-99-2
21	Float Rod	27232-00-8
22	Gasket-Lower Motor	20716-00-7
23	Grid Plate	27228-00-6
24	Float	27205-00-4
25	Lid Latch	85501-01-3
26	Lid Cage & Latch Assembly	27260-14-0
27	Screw #8 x 3/4 Ph Pan Hd Type AB	15039-99-3
28	Foam Sleeve	90585-62-2
29	Reusable Dry Filter	90107-62-4
30	Filter Ring	30065-00-7
31	Pump Adapter Kit (includes items 33 & 34)	27730-96-9
32	Collection Bag (pkg. of 3)	90663-62-6
33	Screen	27237-00-7
34	Cage Bottom	27225-00-2
35	Accessory Tool Holder	84113-00-0
36	Tank Assembly	10469-97-1
37	Drain Cap	10620-21-9
38	Caster Foot	85651-01-6
39	Caster Retainer	85655-00-9
40	Castors (pkg. of 4)	67742-00-7
41	O-Ring	74041-99-7
42	O-Ring	74040-99-9
43	Strip Gasket	20711-00-8

### STANDARD ACCESSORIES

- 7' x 1 1/4" hose with curved end and air diffuser
- 2 - 1 1/4" extension wands
- 10" wet/dry nozzle
- 10" squeegee insert

### THREE-YEAR HOME USE WARRANTY

Your Shop-Vac® vacuum cleaner is warranted in normal household use, in accordance with the User Manual, against original defects in material and workmanship for a period of three years from date of purchase. Should this product be used for commercial or rental use, a 90 day limited warranty will apply. Shop-Vac Corporation warrants placing this vacuum cleaner in correct operating condition, by repair or parts replacement, during the warranty period, without charge. This warranty does not cover accessories. Use of non-recommended filters and/or accessories may void the manufacturer's warranty.

Rev. 10/98  
SC87516-54

# Model QPV 10.5

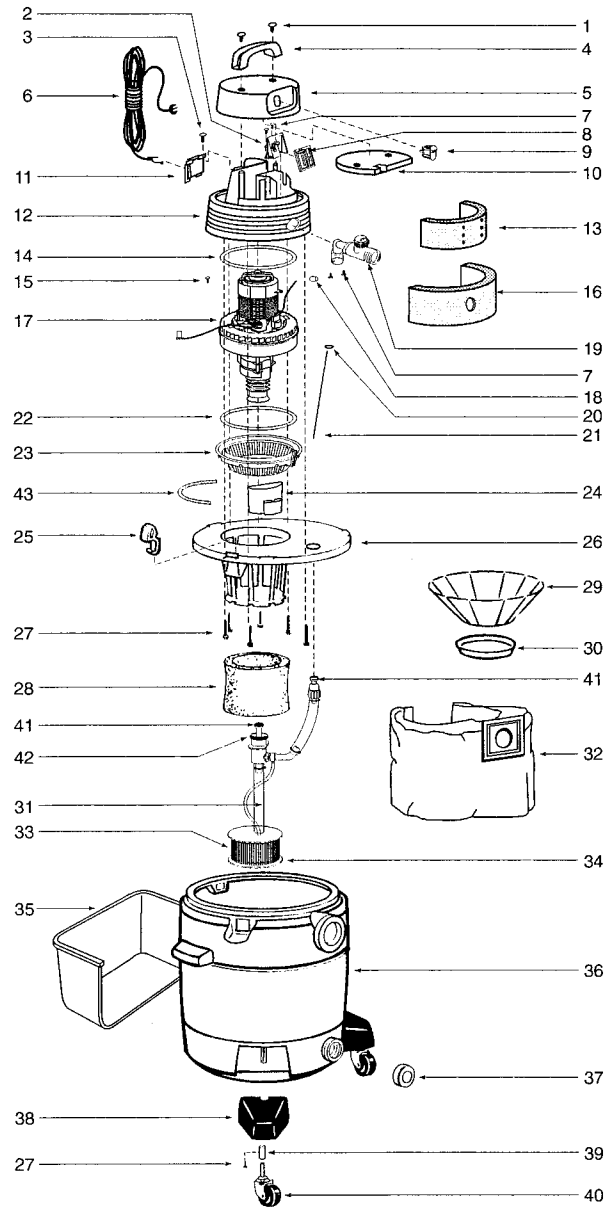

ITEM	DESCRIPTION	PART NO.
1	Screws Truss Head 1/4 x 3/4 Type AB	15146-99-6
2	Switch Assembly	27702-96-8
3	Screw #8 x 1/2 Ph Pan Hd Type AB	15007-99-0
4	Handle	24105-01-7
5	Motor Housing Cover	24106-04-9
6	Cord	25800-08-7
7	Screw #8 x 3/4 Ph Pan HD	15005-99-4
8	Link	27201-00-3
9	Switch Cover and Actuator Assembly	27740-96-8
10	Foam Insert Cover	24125-00-7
11	Cord Retainer	24111-15-5
12	Motor Housing	24107-67-4
13	Foam Motor Housing - Inner	12904-00-9
14	Gasket - Upper Motor	20700-00-1
15	Ground Screw	17008-99-5
16	Foam Motor Housing - Outer	27241-00-9
17	Motor	18167-97-3
18	Wire Nut	05001-99-5
19	Shut-Off Assembly	27700-96-2
20	O-Ring	74029-99-2
21	Float Rod	27232-00-8
22	Gasket-Lower Motor	20716-00-7
23	Grid Plate	27228-00-6
24	Float	27205-00-4
25	Lid Latch	85501-01-3
26	Lid Cage & Latch Assembly	27260-14-0
27	Screw #8 x 3/4 Ph Pan Hd Type AB	15039-99-3
28	Foam Sleeve	90585-62-2
29	Reusable Dry Filter	90107-62-4
30	Filter Ring	30065-00-7
31	Pump Adapter Kit (includes items 33 & 34)	27731-96-7
32	Collection Bag (pkg. of 3)	90662-62-8
33	Screen	27237-00-7
34	Cage Bottom	27225-00-2
35	Accessory Basket	85642-00-7
36	Tank Assembly	10470-97-9
37	Drain Cap	10620-21-9
38	Caster Foot	85651-01-2
39	Caster Retainer	85655-00-9
40	Casters (pkg. of 4)	67742-00-7
41	O-Ring	74041-99-7
42	O-Ring	74040-99-9
43	Strip Gasket	20711-00-8

### STANDARD ACCESSORIES

- 7' x 1/4" hose with curved end and air diffuser
- 2 - 1/4" extension wands
- 10" wet/dry nozzle
- 10" squeegee insert

### THREE-YEAR HOME USE WARRANTY

Your Shop-Vac® vacuum cleaner is warranted in normal household use, in accordance with the User Manual, against original defects in material and workmanship for a period of three years from date of purchase. Should this product be used for commercial or rental use, a 90 day limited warranty will apply. Shop-Vac Corporation warrants placing this vacuum cleaner in correct operating condition, by repair or parts replacement, during the warranty period, without charge. This warranty does not cover accessories. Use of non-recommended filters and/or accessories may void the manufacturer's warranty.

# Model QPV 10.5

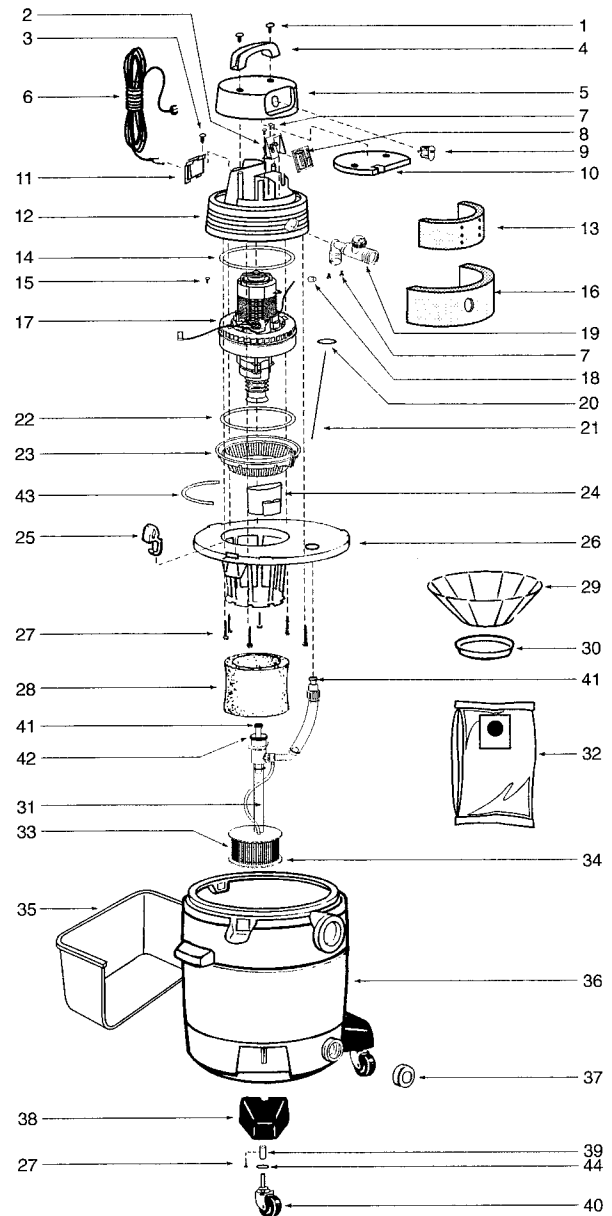
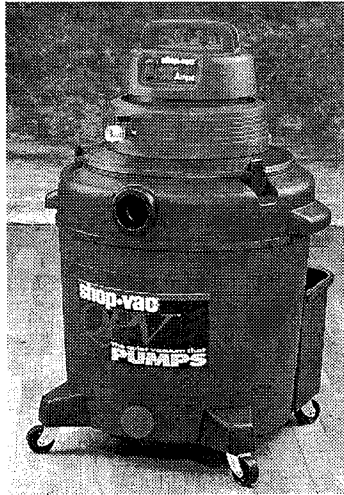

ITEM	DESCRIPTION	PART NO.
1	Screws Truss Head 1/4 x 3/4 Type AB	15146-99-6
2	Switch Assembly	27702-96-8
3	Screw #8 x 1/2 Ph Pan Hd Type AB	15007-99-4
4	Handle	24105-01-7
5	Motor Housing Cover	24106-04-9
6	Cord	25800-08-7
7	Screw #8 x 3/4 Ph Pan HD	15005-99-4
8	Link	27201-00-3
9	Switch Cover and Actuator Assembly	27740-96-8
10	Foam Insert Cover	24125-00-7
11	Cord Retainer	24111-15-5
12	Motor Housing	24107-67-4
13	Foam Motor Housing - Inner	12904-00-9
14	Gasket - Upper Motor	20700-00-1
15	Ground Screw	17008-99-6
16	Foam Motor Housing - Outer	27241-00-9
17	Motor	18167-97-3
18	Wire Nut	05001-99-5
19	Shut-Off Assembly	27700-96-2
20	O-Ring	74029-99-2
21	Float Rod	27232-00-8
22	Gasket-Lower Motor	20716-00-7
23	Grid Plate	27228-00-6
24	Float	27205-00-4
25	Lid Latch	85501-01-3
26	Lid Cage & Latch Assembly	27260-14-0
27	Screw #8 x 3/4 Ph Pan Hd Type AB	15039-99-3
28	Foam Sleeve	90585-62-2
29	Reusable Dry Filter	90107-62-4
30	Filter Ring	30065-00-7
31	Pump Adapter Kit (includes items 33 & 34)	27732-96-5
32	Collection Bag (pkg. of 3)	90663-62-6
33	Screen	27237-00-7
34	Cage Bottom	27225-00-2
35	Accessory Basket	85642-02-3
36	Tank Assembly	10470-97-9
37	Drain Cap	10620-21-9
38	Caster Foot	85651-00-8
39	Caster Retainer	85655-00-7
40	Casters (pkg. of 4)	67736-00-9
41	O-Ring	74041-99-7
42	O-Ring	74040-99-9
43	Strip Gasket	20711-00-8
44	Flat Washer	07043-99-5

### STANDARD ACCESSORIES

- 7' x 1 1/4" hose with curved end and air diffuser
- 2 - 1 1/4" extension wands
- 10" wet/dry nozzle
- 10" squeegee insert

### THREE-YEAR HOME USE WARRANTY

Your Shop-Vac® vacuum cleaner is warranted in normal household use, in accordance with the User Manual, against original defects in material and workmanship for a period of three years from date of purchase. Should this product be used for commercial or rental use, a 90 day limited warranty will apply. Shop-Vac Corporation warrants placing this vacuum cleaner in correct operating condition, by repair or parts replacement, during the warranty period, without charge. This warranty does not cover accessories. Use of non-recommended filters and/or accessories may void the manufacturer's warranty.

shop·vac<sup>®</sup>

Catalog 925-96

# Model QPV 10.5A

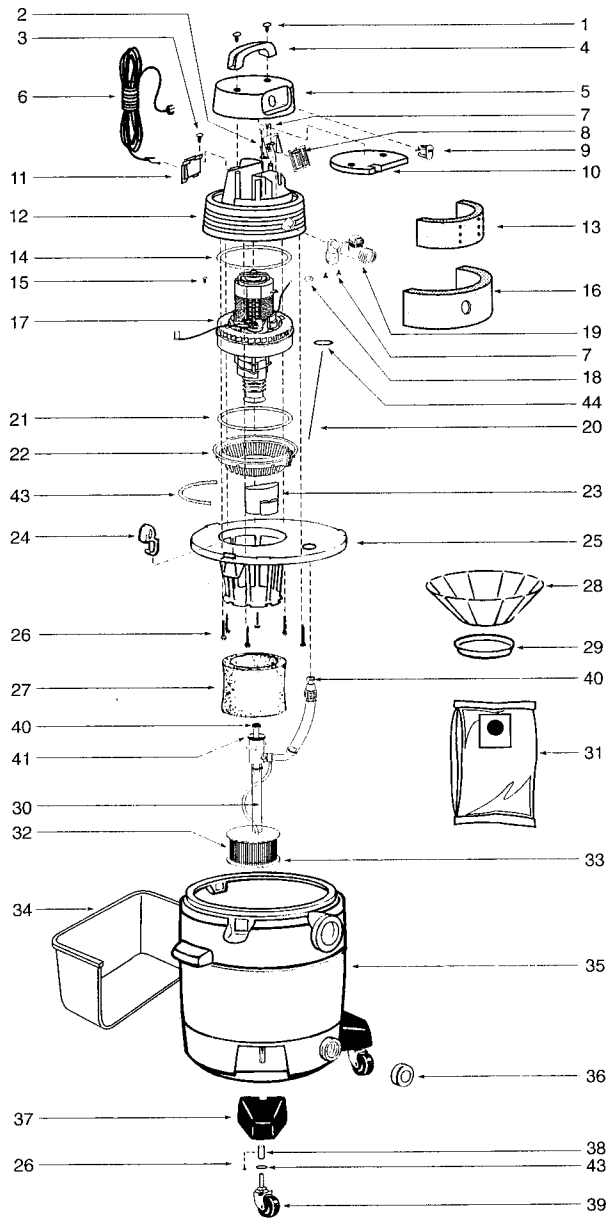
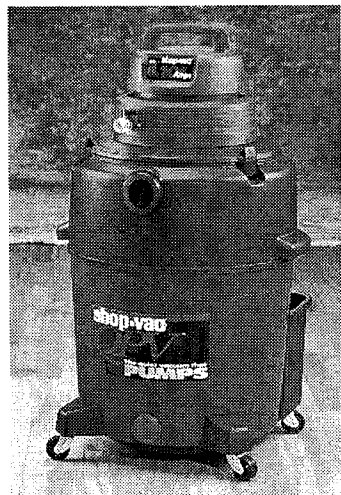

ITEM	DESCRIPTION	PART NO.
1	Screws Truss Head 1/4 x 3/4 Type AB	15146-99-6
2	Switch Assembly	27702-96-8
3	Screw #8 x 1/2 Ph Pan Hd Type AB	15007-99-4
4	Handle	24105-01-7
5	Motor Housing Cover	24106-04-9
6	Cord	25800-08-7
7	Screw #8 x 3/4 Ph Pan	15005-99-4
8	Link	27201-00-3
9	Switch Cover and Actuator Assembly	27740-96-8
10	Foam Insert Cover	24125-00-7
11	Cord Retainer	24111-15-5
12	Motor Housing	24107-67-4
13	Foam Motor Housing - Inner	12904-00-9
14	Gasket - Upper Motor	20700-00-1
15	Ground Screw	17008-99-6
16	Foam Motor Housing - Outer	27241-00-9
17	Motor	18167-97-3
18	Wire Nut	05001-99-5
19	Shut-Off Assembly	27700-96-2
20	Float Rod	27232-00-8
21	Gasket-Lower Motor	20720-02-5
22	Grid Plate	27228-00-6
23	Float	27205-00-4
24	Lid Latch	85501-01-3
25	Lid Cage & Latch Assembly	27260-14-0
26	Screw #8 x 3/4 Ph Pan Hd Type AB	15039-99-3
27	Foam Sleeve	90585-62-1
28	Reusable Dry Filter	90107-62-4
29	Filter Ring	30065-00-7
30	Pump Adapter Kit (includes items 33 & 34)	27733-96-3
31	Collection Bag (pkg. of 3)	90663-62-6
32	Screen	27237-00-2
33	Cage Bottom	27225-00-2
34	Accessory Basket	85642-02-3
35	Tank Assembly	10472-97-5
36	Drain Cap	10620-21-9
37	Caster Foot	85651-00-8
38	Caster Retainer	85656-00-7
39	Castors (pkg. of 4)	49000-96-1
40	O-Ring	74041-99-7
41	O-Ring	74040-99-9
42	Strip Gasket	20711-00-8
43	Flat Washer	07043-99-5
44	O-Ring	74029-99-2

### STANDARD ACCESSORIES

- 7' x 1 1/4" hose with curved end and air diffuser
- 6" x 2 1/2" hose
- 14" squeegee insert
- 2 - 1 1/4" extension wands
- 2 - 2 1/2" extension wands
- 6" utility nozzle
- 10" wet/dry nozzle
- 10" squeegee insert
- 14" floor nozzle
- crevice tool

### THREE-YEAR HOME USE WARRANTY

Your Shop-Vac<sup>®</sup> vacuum cleaner is warranted in normal household use, in accordance with the User Manual, against original defects in material and workmanship for a period of three years from date of purchase. Should this product be used for commercial or rental use, a 90 day limited warranty will apply. Shop-Vac Corporation warrants placing this vacuum cleaner in correct operating condition, by repair or parts replacement, during the warranty period, without charge. This warranty does not cover accessories. Use of non-recommended filters and/or accessories may void the manufacturer's warranty.