

shop-vac®

# Model 90L600

Catalog 9301611 LOWES  
(16 Gal.)



| ITEM | DESCRIPTION                         | PART NO. |
|------|-------------------------------------|----------|
| 1    | Handle                              | 3753000  |
| 2    | Switch Button - Red                 | 7441510  |
| 3    | Switch Button - Green               | 7441500  |
| 4    | Spring                              | 2802899  |
| 5    | Motor Cover Assembly                | 3747011  |
| 6    | Screw 10 x 3/4" Trilobe T25 Head    | 1516599  |
| 7    | Power Unit Assembly                 | 8130997  |
| 8    | Float                               | 3545000  |
| 9    | Lid Latch                           | 7441600  |
| 10   | Lid Cage and Latch Assembly         | 3547050  |
| 11   | Foam Sleeve                         | 9058562  |
| 12   | Cartridge Filter (Includes item 13) | 9030462  |
| 13   | Filter Retainer                     | 3008000  |
| 14   | Tank Assembly                       | 7395197  |
| 15   | Inlet Deflector                     | 7413100  |
| 16   | Rear Wheel Dolly/Tool Holder        | 7440210  |
| 17   | Axle                                | 7410900  |
| 18   | Rear Wheel                          | 7440400  |
| 19   | Accessory Basket                    | 9065800  |
| 20   | Front Caster Dolly                  | 7430250  |
| 21   | Retainer                            | 8565700  |
| 22   | Caster                              | 6773900  |
| 23   | Screw 10 x 3/4" SL Hex Head         | 1503999  |
| 24   | Drain Cover                         | 7443422  |

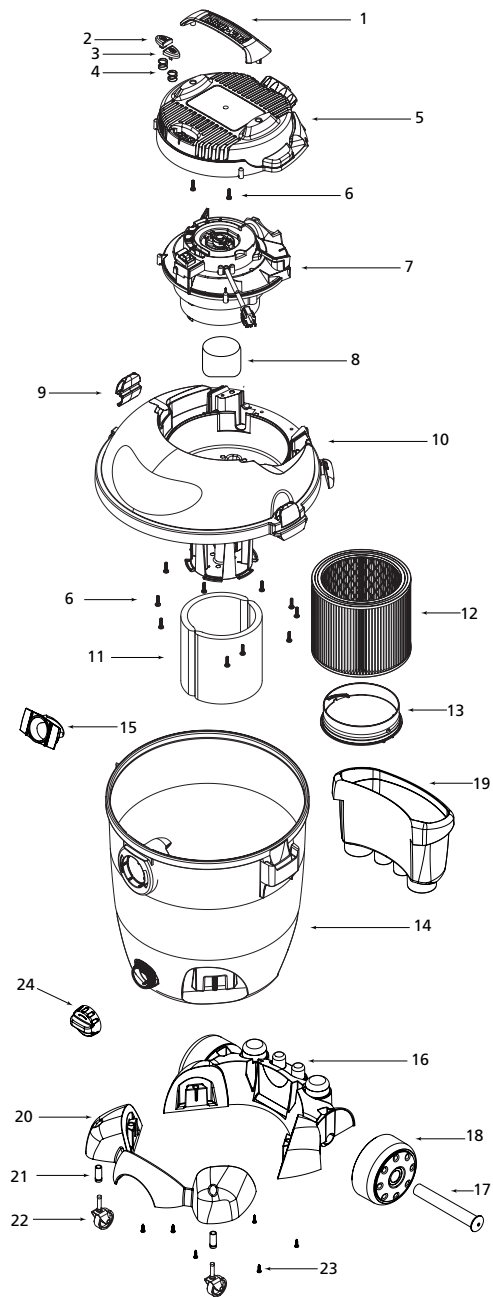

#### STANDARD ACCESSORIES

- 8' x 2-1/2" hose
- 2 - 2-1/2" extension wands
- 14" floor nozzle w/brush

- 14" squeegee insert
- 2-1/2" crevice tool
- 8" utility nozzle
- hose holder

#### FIVE-YEAR HOME USE WARRANTY - SATISFACTION GUARANTEED

Your Shop-Vac® vacuum cleaner is warranted in normal household use, in accordance with the User Manual, against original defects in material and workmanship for a period of five years from date of purchase. Should this product be used for commercial or rental use, a 90 day limited warranty will apply. Shop-Vac Corporation warrants placing this vacuum cleaner in correct operating condition, by repair or parts replacement, during the warranty period, without charge. This warranty does not cover accessories. Use of non-recommended filters and/or accessories may void the manufacturer's warranty.

SC87528-42